

The Atlas Copco logo is positioned in the top left corner of the page. It consists of the brand name "Atlas Copco" in a blue, serif font, centered between two horizontal blue bars. The background of the entire page is a photograph of a construction site. In the foreground, a yellow and black Atlas Copco surface dewatering pump sits on a gravelly bank. A large blue discharge pipe extends from the pump down the slope. In the middle ground, a body of water reflects the sky and the surrounding landscape. The background features a line of trees and a tall electrical transmission tower under a clear blue sky. In the bottom right corner, there is a white, semi-transparent graphic element containing a technical drawing of a pump assembly and the text "Surface dewatering pumps solutions" and "PAS and VAR ranges".

# Surface dewatering pumps solutions

PAS and VAR ranges

# Surface dewatering pumps

The surface dewatering pumps range are designed and developed to offer high performance, reliability and ease of use across multiple industries for applications like construction and mine site dewatering, removing floodwater, and other municipal applications.

At Atlas Copco, we understand pumps, their application and most importantly, the people using them. We have a complete range of diesel and electric driven pumps, that offer durability and long life. Modular design offers flexibility in packaging and easy servicing of wear components means less down time and more pumping without stopping.



UP TO **100 mm**  
SOLIDS  
HANDLING

**24 HOURS**  
OF CONTINUOUS  
OPERATION

UP TO **76 mm**  
SOLIDS  
HANDLING

MAX. HEAD  
UP TO  
**75 m**

COMPACT  
**SIZE**  
with maximum flow

MAX. HEAD  
UP TO  
**40 m**

MAX.  
FLOW UP TO  
**2100 m<sup>3</sup>/h**

MAX.  
FLOW UP TO  
**1400 m<sup>3</sup>/h**

HINGE DOOR  
**3 min**  
CLEAN-UP  
AND RESTART

FLUSHING  
MECH SEAL  
**1 min**  
CLEAN-UP

# There is a surface pump for any surface dewatering application



## 1. Oil & Gas

Pipelines used to transport crude oil or natural gas must be dewatered to guarantee the quality of the hydrocarbons and prevent the formation of hydrates and protect pipes from internal corrosion.

Ballasting process requires robust high performing pumps which, based on the needs, pumps sea water in and out of the shipyard tank during the loading and unloading of water vessels.

### Application

- Ballasting
- Pipeline hydrostatic test
- Drilling
- Pipeline flushing



## 2. Mining and Quarry

For dewatering applications in the mines post dredging, our pumps offer effective and efficient solutions due to their solids handling capability.

### Application

- Dewatering
- Water relaunching
- Washplants
- Slit and Sludge removal



## 3. Municipalities

Municipal public service applications can vary from sewage bypass to wastewater treatment plants to water reclamation centers. When wastewater is being treated, our pumps handle the fluids and solids without clogging or failing.

### Application

- Sewage bypass
- Dewatering
- Emergency water treatment



## 4. Construction

On Construction site, during casting of foundation it becomes critical to avoid water infiltration. Our pumps have got you covered.

### Application

- Site drainage
- Jetting



## 5. Industry

The effluent produced by different industries should be treated, relaunched or drained. With the availability of different materials for our wet ends, we offer a complete solution.

### Application

- Effluent handling and transporting.
- Waste drainage and disposals.
- Temporary firefighting protection.



## 6. Civil works

Modern day civil engineering projects are fast paced. Be it construction of road, dams, bridges, airports or building, site dewatering and drainage, before and during construction work is very important.

### Application

- Sump water removal
- Dewatering



## 7. Floods controls

Our pumps, due to their high performance and portability, are effective to provide quick solutions in case of flood emergency.

### Application

- Emergency



## 8. Wellpoint

All the areas with high ground water level needs to be reduced before the initial digging up of the land. Our pumps can be installed on a side or around the excavation site.

### Application

- Groundwater level reduction
- Pipeline on-shore
- Polluted soil remediation
- Tunneling



## 9. Rental

Rental application requires robust and long running products. Our start and forgot control panels and more than 24 hours fuel autonomy make them ideal for such applications

### Application

- General construction
- Flood controls
- Industry
- Mine and quarry dewatering

# PAS range

The **PAS range** of dry prime pumps are engineered to offer high performance in any conditions. Comprising of a air separator unit and a vacuum pump, it offers rapid automatic priming. Even with suction heights of several meters, the machine rapidly evacuates the air from the suction pipe and starts to pump.

Additionally, thanks to the semi-open impeller, the **PAS range** is also suitable for pumping liquids with solids in suspensions.

## SERVICEABILITY IN ANY CONDITIONS

- Patented Hinged door access guarantees easy clean-up with minimal downtime.
- All wear components are easily accessible with minimal downtime.
- Easy replacement of the wear components (Impeller and wear plates).
- Trimming plate to guarantee the hydraulic performance as an emergency reserve, before scheduled maintenance.

**EASY  
MAINTENANCE**  
**3 MIN  
CLEAN-UP**



## PACKAGING FLEXIBILITY

- One-by-one stackability in standard canopy and open version.
- Mobility, with heavy-duty skids and road trailer equipped for a range of conditions.

**STACKABILITY**



## INTEGRATED CONTROL AND POWER CUBICLE

- Digital controller with standard warnings, shutdown, stop/start function, emergency stop and easy-to-access and read diagnostics. Configurable set point via transducer to control engine speeds\*



## SOLIDS HANDLING CAPABILITY

- The whole range can handle high solids.



## FLEX-MOUNT SYSTEM

- Integrated vibration mounts eliminate unwanted vibration.

## Key options

- Impeller CF3M
- Wear plate CF3M
- Stainless steel shaft
- Zinc anodized

## Key features

- Hinge Kit
- Trimming plate\*
- Diaphragm vacuum pump
- Dry running system
- PW 250, PW500, PW 750 control panel\*

\* Available options may change depending on model selected.

# VAR range

The **VAR range** of wet prime pumps offer a robust and flexible solution for dewatering applications. The technology allows to have a simple first prime due to its first water fill in capabilities.

Due to its open impeller and solids handling capabilities, the equipment perfectly suits for medium construction and flood controls.

## WET PRIME SYSTEM

- The system allows the unit to prime in any conditions through first water fill.
- The liquid rings formed evacuate air for quick priming

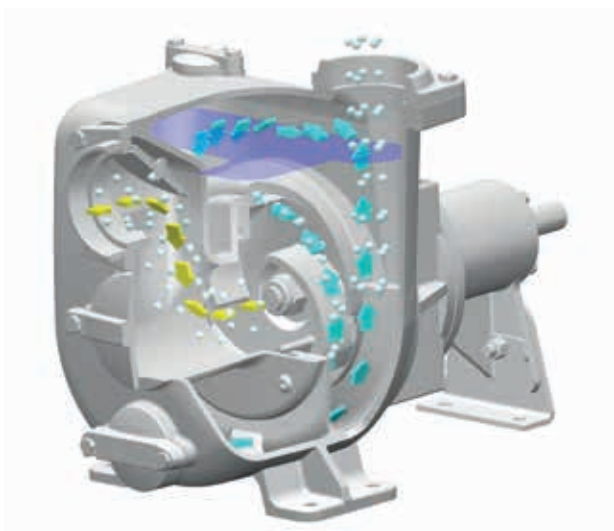

## MOBILITY PACKAGE

- Open-frame version available.



## MECHANICAL SEAL FLUSHING

- Integrated port on pump casing to flush the mechanical seal.
- Solution guarantees the right start up of the units and helps prevent possible casing failure due to fluid solidification.



## SOLIDS HANDLING CAPABILITY

- The whole range can handle high solids.



## Key options

- Impeller CF3M
- Wear plate CF3M
- Stainless steel shaft
- Zinc anodized

## FLEX-MOUNT SYSTEM

- Integrated vibration mounts eliminate unwanted vibration.

# PAS range

## Technical data



StageV

StageV

StageV

Specifications		PAS 80MF 202	PAS 100MF 250	PAS 150MF 250	PAS 200MF 310	PAS 300MF 401	PAS 100HF 250	PAS 150HF 300	PAS 200HF 305	PAS 300HF 440
Max. head	m	19	36	37	36	25	51	51	50	75
Max. capacity	m <sup>3</sup> /h	160	250	540	660	1200	280	520	850	2160
Suction /discharge size		DN80 (3")	DN100 (4")	DN150 (6")	DN200 (8")	DN300 (12")	ANSI 4"	ANSI 6"	ANSI 8"	DN300 (12")
Max. solids handling	mm	40	50	76	76	100	76	76	76	89
Best efficiency point	%	68	70	77	70	60	70	70	75	72
Max. absorbed power	kW	7,5	17	27	40	65	29	51	78	210

Engine										
Emission compliance		Stage V	Stage IIIA	Stage IIIA	Stage V	Stage IIIB	Stage IIIB	Stage V	Stage IV	Stage IV
Max. engine power	kW	8,6	24,3	28,4	55	100	31,0	51,2	79,1	210
Max. operating speed	rpm	1800	2000	2000	2000	1500	2200	2200	2200	1600
Max. fuel autonomy	h	120	51	48	45	24	45	27	22	12

Weight and dimensions										
Weight (dry)	kg	900	1260	1400	1650	2600	1380	1680	2250	4200
Length	mm	1850	2250	2250	2560	2610	2560	2560	2610	3900
Width	mm	1100	1100	1100	1100	1225	1100	1100	1225	2200
Height	mm	1480	1550	1550	1705	1840	1705	1705	1840	2000

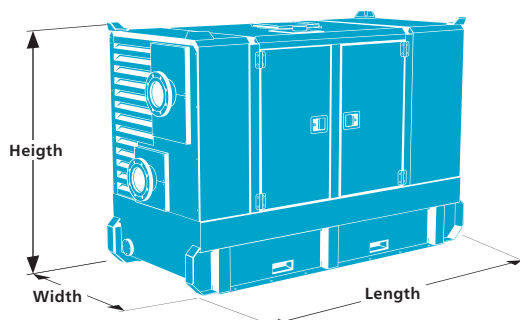

LOOKING FOR ELECTRIC?\*

**E-Pump** OPTIONS  
ALSO AVAILABLE

\* Please consult with your local representative.

# VAR range

## Technical data



Specifications		VAR 4-250	VAR 6-250	VAR 8-305	VAR 10-305	VAR 12-400
Max. head	m	40	33	35	39	29,3
Max. capacity	m <sup>3</sup> /h	180	340	560	690	1400
Suction / discharge size		Threaded 4" BSP	Flanged DN 150 D.I. 1882 (6")	Flanged DN 200 UNI 6082 (8")	Flanged DN 250 D.I. 1882 (10")	Flanged DN 300 UNI 6082 (12")
Max. solids handling	mm	50	76	76	76	70
Best efficiency point	%	65	60	53	70	54
Max. absorbed power	kW	16,5	25	31	45	85,5

Engine						
Emission compliance		Stage IIIA	Stage IIIA	Stage IIIB	Stage IV	Stage IV
Max. engine power	kW	24,3	28,4	33,6	47,7	79,1
Max. operating speed	rpm	2000	2000	1800	1800	1150
Max. fuel autonomy	h	48	42	50	47	29

Weight and dimensions <sup>(1)</sup>						
Weight (dry)	kg	905	935	1205	1850	2125
Length	mm	1750	1750	2500	2800	2800
Width	mm	950	950	950	1450	1450
Height	mm	1520	1520	1850	1850	1850

(1) Dimensions refer to Block model. Please refer the data sheet with overall dimensions with options

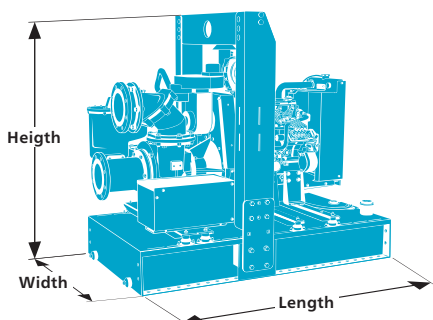

LOOKING FOR ELECTRIC?\*

**EID-Pump** OPTIONS  
ALSO AVAILABLE

\* Please consult with your local representative.